



QUON 11-Litre

CD 25 400

6x2 Rigid



SPECIFICATIONS

Power:	294 kW (400 PS) @ 1600 rpm
Torque:	GH11TB - 2000 Nm (1475 lb.ft) @ 950 rpm
Transmission:	ESCOT-VI automated manual transmission (AMT)
Suspension:	Air bag suspension
Wheelbase:	5800 mm (V-wheelbase)
GVM:	25,000 kg
GCM:	45,000 kg

QUON UNIQUE FEATURES



NEW SMART FUEL EFFICIENT ENGINES WITH RESPECT FOR THE ENVIRONMENT

GH11 engine: fuel efficient, powerful and clean



SMART UPTIME

Quon has been designed to further optimise uptime, with superior reliability and increased maintenance intervals.



SMART SAFETY

Active safety with mechanical and electronic features throughout, including safety for vulnerable road users.



SMART PRODUCTIVITY

Light weight chassis helping to maximise payload. New engines with improved horsepower and torque to increase productivity.



SMART DRIVABILITY

The cabin has been designed with the user's comfort in mind, with outstanding ergonomics and visibility allowing the driver to concentrate on driving

GENERAL SPECIFICATIONS

SAFETY

Passive Safety: Highly rigid cabin
Side door beams
Front underrun protection system (FUPS)
SRS driver steering wheel airbag
Driver side seat belt with pre-tensioner
Steering wheel & column with impact absorption function

Active Safety: Traffic Eye Brake System
Traffic Eye Cruise Control with auto stop and driver initiate go
LDWS (Lane Departure Warning System)
Electronic Stability Control (UDSC)
Automatic Hill Start Assist (HSA)
Lane change support LHS & RHS
Blind side information system LHS & RHS

Basic Safety: LED Headlamps
Disc brakes
Anti Locking Brake System
Emergency Braking System
UD Extra Engine Braking (UD EEB)
Safe Brake Blending Immobiliser
Two-step entry and exit

ENGINE

Model: GH11TB
Description: 6 cylinder, 4 stroke diesel engine
Displacement: 10,837 cc
Bore x stroke: 123 mm x 152 mm
Compression ratio: 17.5:1
Max. governed engine speed: 2,100 rpm

GH11TB400PS

294kW (400PS) @ 1,600rpm
2,000Nm (1475 lb-ft)
@ 950 - 1,350rpm

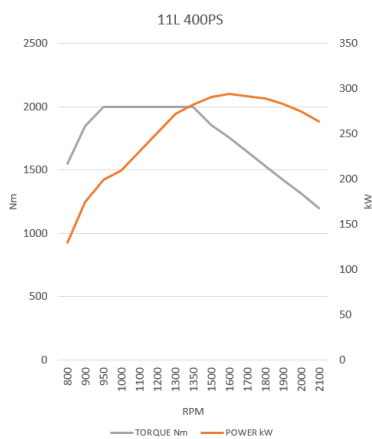

FUEL AND INTAKE SYSTEM

Fuel capacity: 400 litres

Injection type: High pressure common rail direct fuel injection system

Filtration: Chassis mounted primary filter and engine mounted secondary filter

EMISSION CONTROL

Emission standard: pPNLT (equivalent to Euro 6 emission requirements)

Adblue capacity: 50 litres

Exhaust system: RHS chassis mounted box muffler

ELECTRICAL

Power: 24 volt, negative ground system
Battery capacity: 2 x 12 volt 135 Ah batteries
Alternator: 110 amp

TRANSMISSION - ESCOT

Make: UD Trucks
Model: ESCOT-VI (AT2612F)
Description: Automated manual transmission (AMT)
Shift type: 12 forward & 2 reverse gears
Gear ratios: Electronic shifter with fully automatic or manual control

1 st	14.94	7 th	3.44
2 nd	11.73	8 th	2.70
3 rd	9.04	9 th	2.08
4 th	7.09	10 th	1.63
5 th	5.54	11 th	1.27
6 th	4.35	12 th	1.00

Rev 1 17.48 **Rev 2** 13.73
PTO capacity: 1000 Nm @ 70% or 90% (PTR-D)

FRONT AXLE AND SUSPENSION SYSTEM

Ground capacity: 8,200 kg

Axle type: Reverse Elliot I-Beam

Suspension: Parabolic leaf spring with shock absorbers

Spring dimensions: 90mm x 1460mm

Spring constant: 347.7 N/mm

REAR AXLE AND SUSPENSION SYSTEM

Ground capacity: 20,000 kg

Axle type / model: Single reduction, hypoid gear, with diff lock

Final reduction ratio: 3.08 or 3.36

AIR SUSPENSION

Description: 8 air bag

Shock absorbers: 4 telescopic double acting

Road friendly certification number: RF2099 (air only)

Control system: Electronic Controlled Air Suspension with remote control mounted in cab (ECAS4)

BRAKES

Type: Electronic braking system (EBS) with disc brakes on all axles

Front/Rear: 430 mm rotors / 430 mm rotors

Park brakes: Hand-operated pneumatic spring park brake on drive axles

Auxiliary brake: Exhaust plus engine compression type (EEB)

Trailer connections: Air and electrical connections to rear of chassis

STEERING

Type: Recirculating ball and screw with hydraulic assist

Steering gear ratio: 24.1 - 26.8 : 1

Column: Adjustable, tilt and telescopic control

Steering wheel: 460 mm diameter with ignition key steering lock

WHEELS & TYRES

Wheels:	8.25in x 22.5in steel rim with 165mm offset and ISO 10 stud pattern (335mm PCD)
Front tyres:	295/80 R22.5 Bridgestone R150Z
Rear tyres:	11R 22.5 Bridgestone MZ11AZ
Spare tyre:	295/80 R22.5 Bridgestone R150Z

FRAME

Width:	850 mm
Side rail dimensions:	300 mm x 90 mm x 7 mm
Material:	Rolled high tensile carbon steel
Tensile strength:	600MPa / 600N/mm ²

DRIVER INFORMATION & CUSTOMISABLE COLOUR DISPLAY SCREEN

In Dash Warning Systems:	Visual warning lamps with audible warning tones plus written warnings displayed in full colour on the information screen
In Dash Driver Assistance:	Customisable live information includes: On board fuel coaching with economy tips, fuel & AdBlue usage, instant fuel consumption, digital speedo, trip computer including time, distance & distance to empty. Hour meter, coolant temp, engine oil temp, transmission oil temp, UDPC level and volt meter.

INTERNAL CABIN

Lighting:	Dual ON/OFF/DOOR interior lights Interior neon cabin lamp
Seating capacity:	Two (three seats optional)
Driver's seat:	ISRI 6860/875 air suspended seat with integrated seat belt & adjustable arm rest. Adjustable height control & rebound damper. With split seat back adjustments for recline & head rest position. Seat base tilt, seat cushion slide, seat air dump switch. Adjustable air bladders (4) for side bolsters, upper & lower lumbar
Passenger seat/s:	Assistant seat with adjustable back & head rest
Sleeping capability:	ADR 42/04 compliant sleeper bunk with mattress and full curtains
Side windows:	Power operated door glass with auto up & down to driver's window. Isolation switch for passenger side window.
Security:	Remote central locking with immobiliser
Air conditioning:	Fully automatic climate controlled airconditioning with recirculation filter.
Multimedia unit:	8 inch high definition capacitive touchscreen with tilting function, AM-FM radio, digital radio & internet radio (requires phone data), USB & auxiliary ports & PDF reader, standard WDR digital reverse camera with microphone & infra-red function, four additional camera inputs with split screen functionality, Wi-Fi & phone tethering enabled, bluetooth handsfree operation.

Multimedia Unit (continued):	Android connectivity, Apple connectivity with Siri inputs, truck specific satellite navigation with 3 free map upgrades. Options available: cordless Qi rated phone charging pocket, tyre pressure monitoring & reverse sensors
Storage:	Multiple in-cab compartments
Power outlet:	24 volt 240W & 12 volt 120W in dash
DIN accessory fitment:	Two DIN sized compartments
Floor covering:	Vinyl

EXTERNAL CABIN

Cab Description:	Forward control, pressed steel construction
Mounting type:	Full floating, 4 bag air suspended cab with 4 dual acting shock absorbers and dual automatic height control valves
Cab paint:	Standard – "Polar White"
Inspection points:	Back of the cab and front panel
Bumper type:	3 piece with steel corner panels
Mirrors:	Heated & electrically operated main mirrors with flat glass, wide vision & passenger-side downward facing spot mirrors
Lamps:	LED head lamps (low beam) Bumper mounted fog lamps Roof mounted clearance lights
Wipers:	Triple arm, 2 speed wipers with variable intermittent operation & integrated washers
Reversing system:	Reverse beeper and digital infrared camera with microphone

UD CONNECT (FLEET MANAGEMENT)

Telematics hardware:	In-cab GSM and GPS unit with SIM-card connected to roof antenna
Subscription:	12 months included
Key Reports:	Total operational time and distance Average speed and fuel consumption Total CO ₂ emission Vehicle utilisation Anticipating & braking Engine & gear utilisation Speed adaptation Time idling (standstill)

FACTORY OPTIONAL EQUIPMENT

Tyres:	275/70 R22.5
Wheels:	Alcoa aluminium wheels
Rear engine PTO:	DIN 5462 or Flange SAE1410, 650 Nm capacity
Safety:	Driver Alert System Driver Monitoring System
Cab paint:	Custom paint colours
Cab Interior:	Leather steering wheel, Woodgrain dash, Centre console or 2nd passenger seat
Cab Exterior:	Roof scoop, Chrome grille, Roof beacon prep kit, Bumper spoiler, passenger door peep window, cab auxiliary side windows
Additional Wheelbases:	4,700mm, 5,100mm
Chassis:	Front axle stabiliser bar
Additional Fuel Capacity:	2 nd 400 litre Aluminium tank mounted

MAJOR DIMENSIONS

Variant	Mass (kg)				Vehicle Dimensions (mm)															UD order code
	Wheelbase code	GVM*	GCM	Total Tare ¹	WB	TWB	OL	OW	OH	FT	RT	AS	ROH	CA	GC ²	FHF ²	FHR ²	Turning radius (kerb to kerb)		
UD – Air	V	25000	45000	7409	5800	6485	11467	2490	2970	2062	1851	1370	4145	5085	249	1010	1012	9900	CD25400VAA	

*Rated GVM and axle capacities are subject to Federal, State and Territory legal requirements.

¹ Mass is an estimation based only on standard model, includes fluids (no diesel fuel or Adblue®). Excludes spare wheel. Excludes driver and tools. Subject to ± 3% tolerance.

² Based on vehicle with standard wheels and tyres

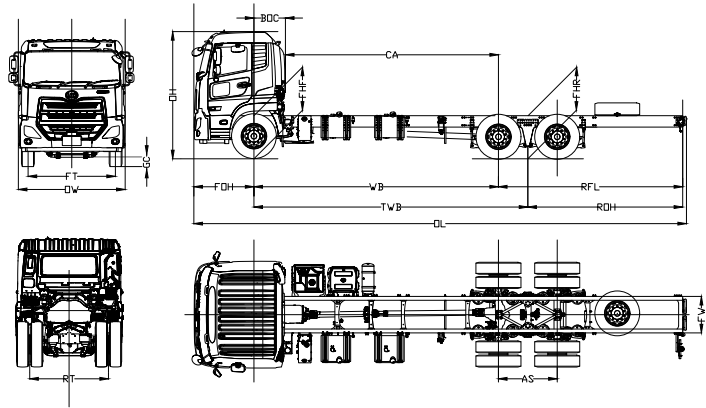

WARRANTY

Standard warranty⁺	36 months / 500,000 kms
Cab corrosion warranty⁺	36 months / unlimited kms
Extended warranty⁺⁺	60 months / 500,000 kms

⁺For details refer to your UD Trucks New Vehicle Warranty brochure

⁺⁺Purchased by the owner and covers selected factory items only. For details refer to your UD Trucks New Vehicle Warranty brochure