



RECALL BULLETIN

DATE: OCTOBER 2, 1995
MODEL YEAR: 1995
MODELS AFFECTED: UD1800/UD2300/UD2600/UD3000
BULLETIN #: SC-176
FILE AT END OF ELECTRICAL SECTION IN TECHNICAL BULLETIN BINDER

VOLUNTARY SAFETY RECALL CAMPAIGN #95V-176
(FORMERLY INTRODUCED AS PI-026 DATED APRIL 19, 1995)

WIRING HARNESS PROTECTOR

MODELS AFFECTED:

UD1800, UD 2300, UD2600, and UD3000 manufactured before February 23, 1995 and not completed under PI-026. Each dealer will receive a computer listing of all affected vehicle numbers either in unsold inventory or delivered to customers by the dealer. The applicable vehicles, by model and VIN, involved in this safety recall are as follows:

UD1800, from JNAMA20HXSGF50001 to JNAMA20H3SGN50726
UD2300, from JNALC20HXSGD50001 to JNALC20H0SGN50480
UD2600, from JNAPA20H7SGN50001 to JNAPA20H1SGN50320
UD3000, from JNAPB20H8SGL50001 to JNAPB20H1SGS50046

DESCRIPTION:

The possibility exists that the vehicles may experience wiring harness protector chafing or rubbing on the driver's side lower frame rail flange, causing possible breakage of the wiring harness protector and exposure or breakage of the wiring. Breakage of the wiring could cause loss of electrical power to various components or systems, including the headlights and windshield wipers.

NOTE: This Recall Bulletin # SC-176 replaces Product Improvement Letter 026 that was announced to the dealer group on or about April 19, 1995.

The repairs to correct this condition consist of the installation of a plastic friction insulator on the lower frame rail flange between the flange and the wiring harness protector. If the protector or any of the wiring has been broken, it should also be repaired.

All owners of the affected vehicles will be notified by mail and instructed to make an appointment with a UD Truck dealer to have this safety recall performed. This repair will be made free of charge to the owner.

The National Highway Traffic Safety Administration has assigned the identification # 95V-176 to this safety recall. This number must appear on all communications and documentation of any nature related to the campaign described in this bulletin.

ADMINISTRATION / DEALER RESPONSIBILITY:

Proceed immediately to make the necessary repair to the affected vehicles in inventory. All inventory vehicles subject to this safety recall must be corrected prior to sale, transfer, or delivery. Each dealer will receive a computer listing of all affected vehicle numbers in either unsold inventory or delivered to customers by the dealer. With this computer listing, the dealer will receive an "Authorization For Recall Notification Service" card for all unsold or undelivered inventory. This card must be filled out correctly and returned to the address on the card whether the vehicle was repaired, transferred, sold, etc. (see Warranty Policies & Procedures Manual, Part III, Section 1, Pages 1-5).

PARTS INFORMATION:

The parts required to complete the repair as described in this Recall Bulletin are available immediately for UD Dealers to order through the NDA Parts Department. Use the attached computer list to order the proper number of the plastic friction insulators to repair the listed vehicles. Each vehicle requires one (1) of the plastic friction insulators installed, as shown in the figure below, with a permanent adhesive, such as Super Glue, 3-Bond, Quicktite, or suitable equivalent.

PART NUMBER	PART NAME	QUANTITY AND APPLICATION
76840 - Z3020	FRICION INSULATOR	1 ea. required for this safety recall

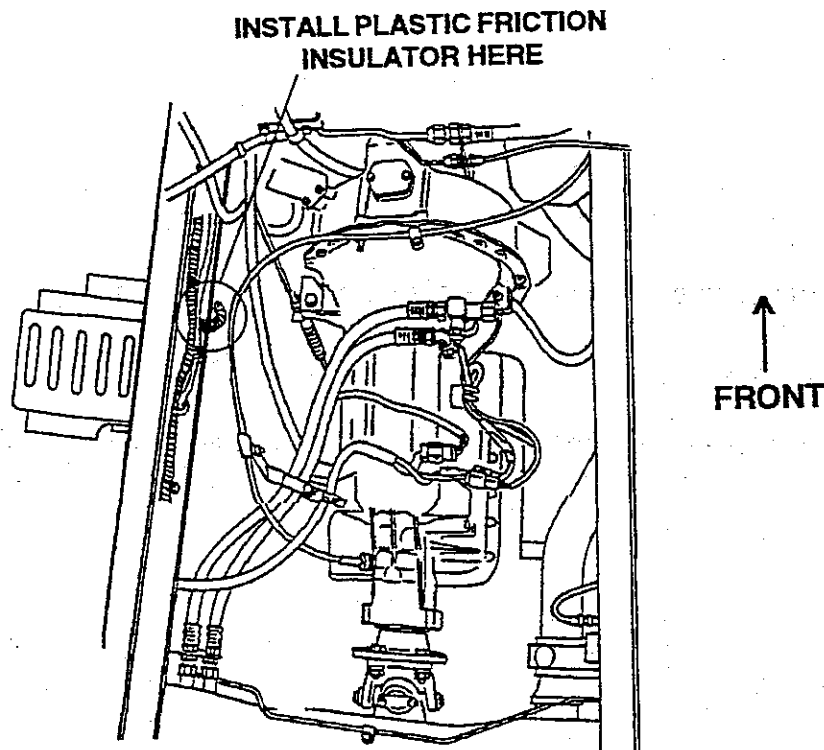

SERVICE INFORMATION:

Install the plastic friction insulator on the frame rail lower flange with a permanent adhesive such as Super Glue, 3-Bond, Quicktite, or a suitable equivalent. The insulator should be centered on the wiring harness as shown in the figure below.

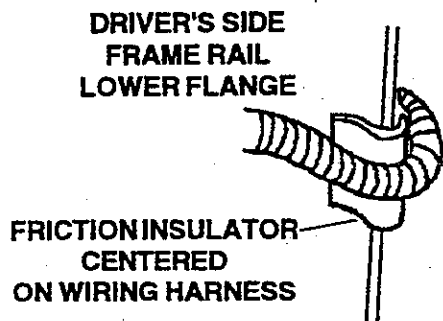

If the wiring harness protector is torn or separated, apply electrical tape to the affected area to seal the harness protector, then install the friction insulator. If any of the wires are exposed or broken, repair the affected wires, apply electrical tape to the affected area of the harness protector, then install the friction insulator.

WARRANTY INFORMATION:

Expenses for the installation of the friction insulator as described in this Recall Bulletin are to be recovered through the standard UD Warranty Claim Procedures as listed in the UD Warranty Policies & Procedures Manual, PART III and PART V. Please attach the "Authorization For Recall Notification Service" card to the UD Warranty Claim Sheet. Use the following special information to prepare your warranty claims:

TROUBLE CODE: 40000121

FAILED PART NUMBER: 24013 - 32Z1X

FAILED PART NAME: HARNESS ASSY.

REPAIR DESCRIPTION: PERFORM VOLUNTARY SAFETY RECALL CAMPAIGN # 95V - 176

LABOR OPERATION NUMBER: 892 - X

LABOR TIME ALLOWED: 0.5 HRS. (INCLUDES INSTALLATION OF FRICTION INSULATOR AND REPAIR OF WIRING HARNESS PROTECTOR. ADDITIONAL TIME MAY BE ALLOWED FOR REPAIRING BROKEN WIRES, IF NECESSARY.)

FOR THE INDICATED PERSONNEL BELOW, PLEASE READ, INITIAL, AND ROUTE TO THE FOLLOWING:					
X	DEALER PRINCIPAL	X	SERVICE MANAGER	X	WARRANTY MANAGER
X	PARTS MANAGER	X	SHOP FOREMAN	X	SERVICE TECHNICIANS INITIAL: <input type="text"/>