

# TECHNICAL BULLETIN TR-19

DATE: JANUARY 16, 2004  
 MODEL YEAR: 1999 AND AFTER  
 TRANSMISSION MODEL: AISIN AUTOMATIC TRANSMISSION  
 BULLETIN NUMBER: TR-19  
 FILE IN THE TRANSMISSION SECTION OF THE TECHNICAL BULLETIN BINDER

## AISIN AUTOMATIC TRANSMISSION OUTPUT FLANGE NUT SERVICE PROCEDURES

### PURPOSE

The following information emphasizes the importance of proper installation and torque setting for the Aisin Automatic Transmission output flange nut. Failure to follow the prescribed procedures will result in damage to the transmission.

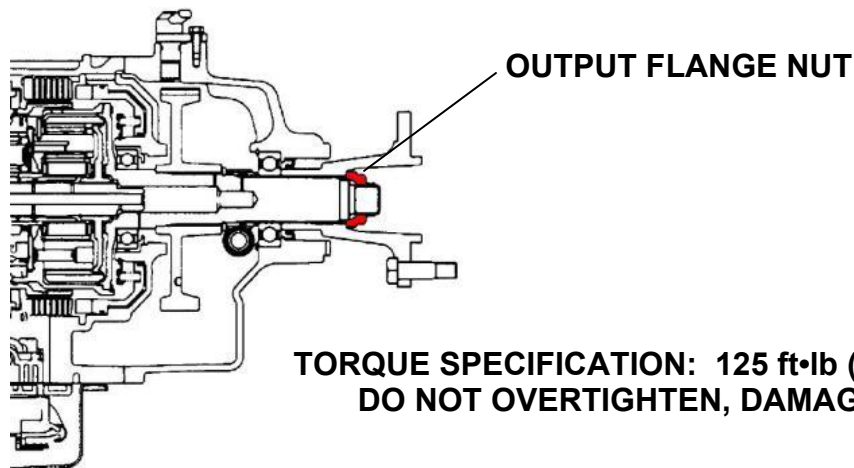

### SERVICE PROCEDURE

Whenever repair or service procedures require the removal of the output flange nut on the Aisin Automatic Transmission, it is required that a new flange nut part number 33143-29D00 and O-ring part number 31526-29D05 be installed.

- Install flange yoke with the end caps 90° to the slotted grooves on the output shaft.
- Lubricate the output shaft O-ring with clean ATF and install over the output shaft in the recess of the output flange yoke.
- Install the output flange nut by hand and then torque to the specified value utilizing a torque wrench only.

### DO NOT USE AN IMPACT WRENCH!

**WARNING:** Do not exceed the specified torque of 125 ft•lb (170 N•m, 17.3 kgf•m).

- Properly stake the output flange nut onto the output shaft as shown on the right using a blunt chisel.

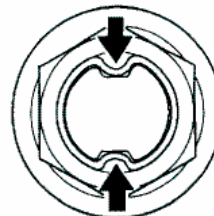

### STAKE NUT WITH CHISEL

THE INFORMATION CONTAINED IN THIS BULLETIN SHOULD NOT BE INTERPRETED AS THE BASIS FOR WARRANTY CLAIMS							
FOR THE INDICATED PERSONNEL BELOW, PLEASE READ, INITIAL, AND ROUTE TO THE FOLLOWING:							
X	SERVICE MANAGER	X	WARRANTY MANAGER	X	SERVICE TECHNICIANS INITIAL BELOW:		
X	PARTS MANAGER	X	SHOP FOREMAN				